

Toward 200G per Lane VCSEL-based Multimode Links

M.V. Ramana Murty^a, Jingyi Wang^a, Sizhu Jiang^a, David Dolfi^a, T.K. Wang^a, Derek Vaughan^a,
Zheng-Wen Feng^b, Nelvin Leong^b, Aadi Sridhara^b, Sumitro T. Joyo^b, Jason Chu^b, and Laura Giovane^a

^aBroadcom Inc., Optical Systems Division, 408 E Plumeria Dr, San Jose, CA 95134, USA

^bBroadcom Inc., Optical Systems Division, 1150 Depot Road, Singapore

E-mail: ramana.murty@broadcom.com

Abstract: Progress in the development of multimode 850 nm VCSELs is demonstrated at 100 GBd PAM4 operation, and at 53.125 GBd PAM4 with transmission over 100 m of OM3 fiber. Continued advances will help introduce the next generation of multimode links. © The Author(s)

1. Introduction

Optical links have witnessed a steady increase in demand in the past 25 years as data rates increased from 1 to 100 Gb/s per wavelength. Advances in high performance computing, enterprise and hyperscale data centers and storage networks have been supported by the development of high bandwidth lasers and communication ICs, and the evolution in communication protocols. Not satisfied with the advances in laser modulation rate, arrays of lasers are now commonly used to target higher aggregate data rates between nodes. Space division multiplexing in the form of four lane and eight lane links is the most popular while a bidirectional link or coarse wavelength division multiplexing is used when fiber count is a limitation. Several data centers have upgraded to 400 GbE in the past few years using a combination of 50 and 100 Gb/s per lane links.

The development of algorithmic artificial intelligence (AI) and large language models for generative AI has accelerated and expanded the demand for optical links. The intensive computation used by AI requires vast arrays of GPU cards networked with short communication links. Multimode optics are ideal for links that extend beyond a few meters, offering the twin advantages of low cost and low power consumption. Directly modulated VCSELs with straight-forward alignment to fiber are a key element of these links.

Figure 1 shows the evolution of 850 nm VCSEL modulation rate over the past 25 years at Broadcom beginning near 1 Gb/s in 1997. The data points fall close to the straight line fit on the semi-log plot indicating an exponential rise in the modulation rate with time and a doubling in approximately four years. This represents the Moore's law for VCSELs, similar to the performance gains observed for several other technologies. Figure 1 also shows the completion of significant IEEE 802.3 multimode Ethernet standards [1] with the latest 802.3db standard defining physical layer specifications for multimode fiber (MMF) links up to 100 m OM4 at the 100 Gb/s lane rate. The demand for higher data rate has not ceased with demonstrations of 200 Gb/s per lane on single mode fiber and copper links, and the ongoing standardization work [2]. Extending the modulation rate to 200 Gb/s faces the challenges of increasing the optical bandwidth and improving the parasitics of the VCSEL while achieving the reliability needed for practical applications. This paper describes the development of VCSELs for 200 Gb/s per lane MMF data links.

2. Experimental Setup

A block diagram of the test setup for large-signal modulation is shown in Fig. 2(a). The modulation signal is generated by either a Keysight M8045A pattern generator or a 256 GSa/s Keysight M8199B arbitrary waveform generator (AWG). The DC bias and AC modulation signals are coupled with a bias-T of 65 GHz bandwidth and delivered to the VCSEL through an RF probe. Light from the VCSEL is coupled into the MMF with microscope optics. An attenuator is inserted into the MMF path for adjusting the optical modulation amplitude (OMA). The optical waveform is analyzed using a Keysight DCA N1092E. The maximum system impulse response correction (SIRC) filter bandwidth on N1092E is 40 GHz. The receiver of a 400 Gb/s SR4 commercial transceiver was used for the bit error ratio (BER) measurements.

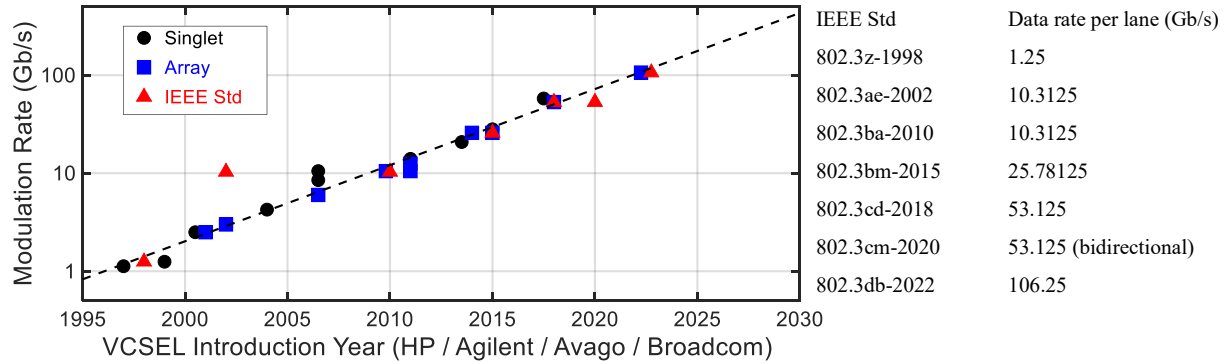

Figure 1. Evolution of the 850 nm VCSEL modulation rate over the past 25 years at Broadcom. VCSELs have been used either as a singlet or an array, with the 1×4 form factor being the most popular. The completion of important IEEE Ethernet standards for MMF links is also shown and closely tracks the VCSEL development.

3. Multimode VCSELs

Today, 800G transceivers based on 100G VCSELs are being deployed in volume in multimode links. While the majority of these links are under 50 m, there are applications that require reach up to 100 m OM4. The performance of an 100 Gb/s VCSEL is demonstrated in Fig. 2(b), which shows the pre-FEC BER after 53.125 GBd PAM4 signal transmission through 100 m OM3 fiber. The VCSEL is biased at 9 mA at room temperature. The center wavelength and RMS spectral width are 856.4 nm and 0.37 nm, respectively. The OM3 fiber used for the measurement had an effective modal bandwidth (EMB) of 2000 MHz·km and the measured -3 dBe fiber bandwidth of 14 GHz. The BER is recorded with a PRBS31Q pattern using a free space attenuator to vary the OMA. The waterfall plot shows pre-FEC BER below 1E-8 at OMA of 0 dBm. The combination of pre-emphasis in the transmitter and adaptive equalization in the receiver helps remove the inter-symbol interference (ISI) even for the very low bandwidth link.

The PAM4 modulation format will continue at 200G per lane in Ethernet single mode fiber and copper links. It is expected that the laser modulation rate will depend on the choice of the forward error correction (FEC) code. Use of the RS (544, 514) end-to-end FEC leads to a modulation rate of 106.25 GBd. The addition of an inner FEC for the optical section of the link provides more margin but adds latency and pushes the modulation rate closer to 113.5 GBd. The adoption of one or both of these FEC codes is presently being debated for single mode links [2]. Multimode links are short and the additional latency from the inner FEC code is likely to be of concern for AI/ML applications. Hence, a modulation rate closer to 106.25 GBd is anticipated for MMF links.

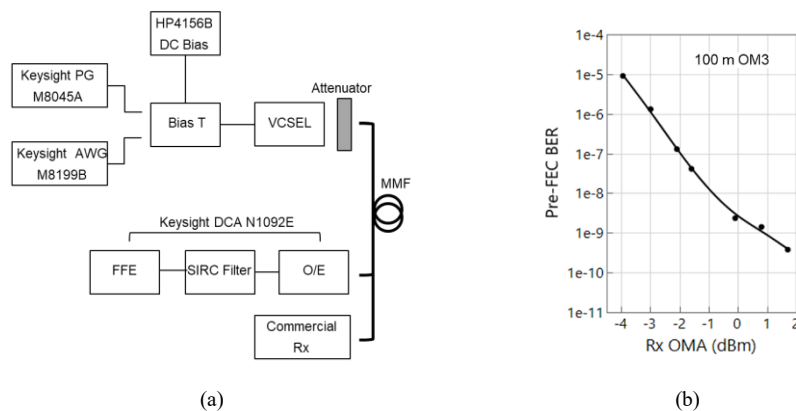

Figure 2. (a) Block diagram of the test setup for large-signal modulation. (b) Pre-FEC BER as a function of OMA at the receiver for 53.125 GBd PAM4 signal transmission over 100 m OM3 fiber. A PRBS31Q pattern was used for the measurement.

The development of VCSELs to target 200G per lane has continued with progress in both device bandwidth and noise performance. The launch OMA needs to be high for a 200G link to account for the reduced receiver sensitivity and that favors the continued use of multimode VCSELs. Panel (a) of Fig. 3 shows a 100 GBd PAM4 eye diagram

from an 850 nm VCSEL collected with a short patch cord. A 7-tap pre-emphasis was used for the drive signal resulting in an extinction ratio of 2.1 dB and the eye diagram is collected with the PRBS13Q pattern. A 64-tap feed forward equalizer (FFE) in the DCA helps reduce ISI to clearly observe the PAM4 levels. The lateral (time) skew of the three sub-eyes in the optical eye diagram arises from the nonlinear response of the directly modulated VCSEL [3]. Panel (b) of Fig. 3 shows a 106.25 Gb/s NRZ eye diagram from an 850 nm VCSEL, again collected with a short patch cord. The extinction ratio is 2.1 dB and the eye diagram is collected with the PRBS13 pattern. A clear open eye is observed after equalization.

A 40 GHz SIRC filter was used in the DCA to collect both the PAM4 and NRZ optical signals in Fig. 3 because a half-baud rate filter was not available. The eye diagrams in Fig. 3 can be considered equivalent to that obtained after transmission through approximately 30 m worst case OM4 fiber (EMB 4700 MHz·km and chromatic dispersion from a 0.6 nm RMS spectral width source).

All components in an optical link including VCSEL, photodiode, MMF and TIA will be challenged by the bandwidth requirements for the 200G link. In addition, nonlinearity arising both from the intrinsic nature of a directly modulated laser and overshoot in the optical waveform leads to a distortion of the signal. Equalization methods such as FFE and maximum likelihood sequence estimation (MLSE) will play a bigger role in the establishment of the 200G link. Advance linearization methods [4,5] are also being developed to counter the nonlinearity of the components. The eye diagrams in Fig. 3 were taken from a VCSEL operating at room temperature. More VCSEL development and the adoption of advanced equalization schemes will help bring the next generation of multimode links.

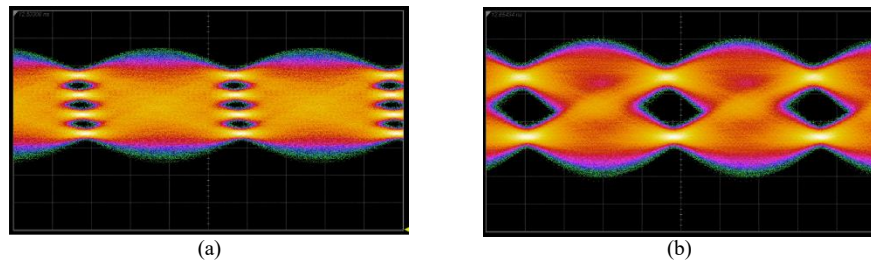

Figure 3. (a) The equalized 100 GBd PAM4 eye diagram from an 850 nm VCSEL with a PRBS13Q pattern. (b) The equalized 106.25 Gb/s NRZ eye diagram with the PRBS13 pattern. A 40 GHz SIRC filter was used in the DCA to collect the eye diagrams. The scale is 2.5 ps/div for the horizontal axis and 500 μ W/div for the vertical axis in both panels.

4. Conclusion

The development of multimode 850 nm VCSELs continues with the demonstration of extended reach at 100G per lane and 100 GBd PAM4 operation. Continued progress will help introduce 200G multimode links.

5. References

- [1] "IEEE Standard for Ethernet," in *IEEE 802.3-2022*, pp. 1 – 7025 (2022).
- [2] *IEEE P802.3dj 200 Gb/s, 400 Gb/s, 800 Gb/s and 1.6 Tb/s Ethernet Task Force*, Available: <http://www.ieee802.org/3/dj/index.html>
- [3] M. V. Ramana Murty, J. Wang, A.-N. Cheng, D. W. Dolfi, Z.-W. Feng, A. Sridhara, S.T. Joyo, J. Chu, and L. M. Giovane, "Development and characterization of 100 Gb/s data communication VCSELs," *IEEE Photon. Technol. Lett.* **33**, 812 – 815 (2021).
- [4] Mayank Raj, M. Monge, and A. Emami, "A modeling and nonlinear equalization technique for a 20 Gb/s 0.7 pJ/b VCSEL transmitter in 32 nm SOI CMOS," *IEEE J. Solid-State Circuits* **51**, 1734 – 1743 (2016).
- [5] N. Bamiedakis, D. G. Cunningham, and R. V. Penty, "Linearisation method of DML-based transmitters for optical communications Part I: Theory and simulation studies," *IEEE J. Lightw. Technol.* **39**, 5815 – 5827 (2021).